

PRO-FORM[®]

380 ZLX

Model No. PFEVEX74108.0

Serial No. _____

Write the serial number in the space above for reference.

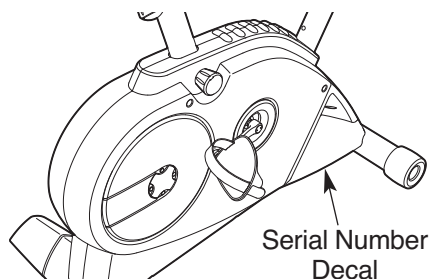

USER'S MANUAL

QUESTIONS?

As a manufacturer, we are committed to providing complete customer satisfaction. If you have questions, or if there are missing parts, please contact us at the numbers or addresses listed below:

Call: 08457 089 009

Outside UK: 0 (44) 113 3877133

Fax: 0 (44) 113 3877125

E-mail: csuk@iconeurope.com

Write:

ICON Health & Fitness, Ltd.

Unit 4

Revie Road Industrial Estate

Revie Road, Beeston

Leeds, LS11 8JG

UK

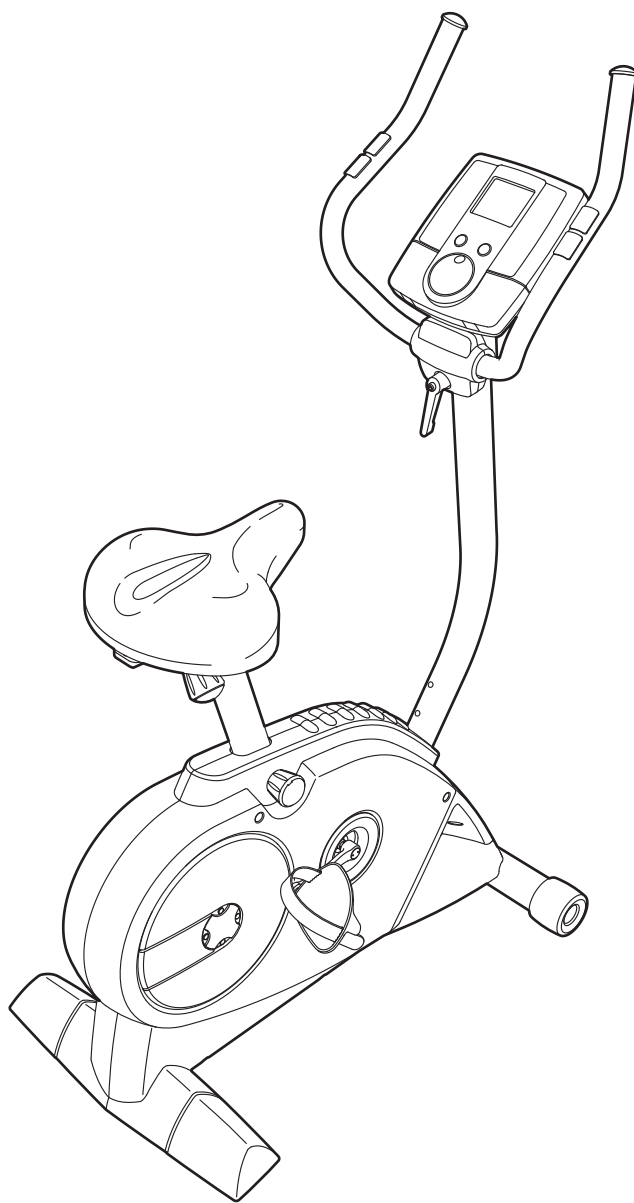

CAUTION

Read all precautions and instructions in this manual before using this equipment. Keep this manual for future reference.



Visit our website at

www.iconeurope.com

TABLE OF CONTENTS

WARNING DECAL PLACEMENT2
IMPORTANT PRECAUTIONS3
BEFORE YOU BEGIN4
ASSEMBLY5
HOW TO OPERATE THE EXERCISE CYCLE12
MAINTENANCE AND TROUBLESHOOTING20
EXERCISE GUIDELINES21
PART LIST22
EXPLODED DRAWING23
ORDERING REPLACEMENT PARTSBack Cover

WARNING DECAL PLACEMENT

This drawing shows the location(s) of the warning decal(s). **If a decal is missing or illegible, call the telephone number on the front cover of this manual and request a free replacement decal. Apply the decal in the location shown.**
Note: The decal(s) may not be shown at actual size.

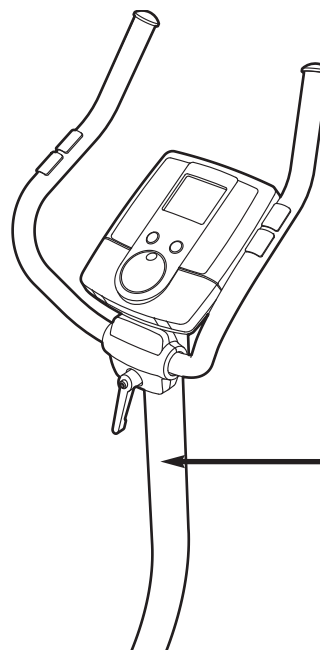

WARNING

- Misuse of this machine may result in serious injury.
- Read user's manual prior to use and follow all warnings and instructions.
- Do not allow children on or around machine.
- Pedals continue to spin when you stop pedaling.
- Spinning pedals can cause injury.
- Reduce pedal speed in a controlled manner.
- User weight must not exceed 275 pounds.
- This product should always be used on a level surface.
- This product is not intended for therapeutic use.
- Replace label if damaged, illegible, or removed.



IMPORTANT PRECAUTIONS

⚠️ WARNING: To reduce the risk of serious injury, read all important precautions and instructions in this manual and all warnings on your exercise cycle before using your exercise cycle. ICON assumes no responsibility for personal injury or property damage sustained by or through the use of this product.

1. Before beginning any exercise program, consult your physician. This is especially important for persons over the age of 35 or persons with pre-existing health problems.
2. It is the responsibility of the owner to ensure that all users of the exercise cycle are adequately informed of all precautions.
3. Your exercise cycle is intended for home use only. Do not use your exercise cycle in a commercial, rental, or institutional setting.
4. Keep your exercise cycle indoors, away from moisture and dust. Place your exercise cycle on a level surface, with a mat beneath it to protect the floor or carpet. Make sure that there is enough clearance around your exercise cycle to mount, dismount, and use it.
5. Inspect and properly tighten all parts regularly. Replace any worn parts immediately.
6. Keep children under age 12 and pets away from your exercise cycle at all times.
7. Your exercise cycle should not be used by persons weighing more than 275 lbs. (125 kg).
8. Wear appropriate exercise clothes while exercising; do not wear loose clothes that could become caught on your exercise cycle. Always wear athletic shoes for foot protection while exercising.
9. When adjusting the seat, insert the adjustment knob into one of the holes in the seat post. Do not insert the seat pin under the seat post.
10. The pulse sensor is not a medical device. Various factors, including the user's movement, may affect the accuracy of heart rate readings. The pulse sensor is intended only as an exercise aid in determining heart rate trends in general.
11. Keep your back straight while using your exercise cycle; do not arch your back.
12. When you stop exercising, allow the pedals to slowly come to a stop.
13. If you feel pain or dizziness while exercising, stop immediately and cool down.
14. Use your exercise cycle only as described in this manual.

BEFORE YOU BEGIN

Congratulations for selecting the new PROFORM® 380 ZLX exercise cycle. Cycling is one of the most effective exercises for increasing cardiovascular fitness, building endurance, and toning the entire body. The 380 ZLX exercise cycle offers a selection of features designed to let you enjoy this healthful exercise in the convenience and privacy of your home.

For your benefit, read this manual carefully before you use the exercise cycle. If you have questions

after reading this manual, please see the front cover of this manual. To help us assist you, note the product model number and serial number before contacting us. The model number and the location of the serial number decal are shown on the front cover of this manual.

Before reading further, please familiarize yourself with the parts that are labeled in the drawing below.

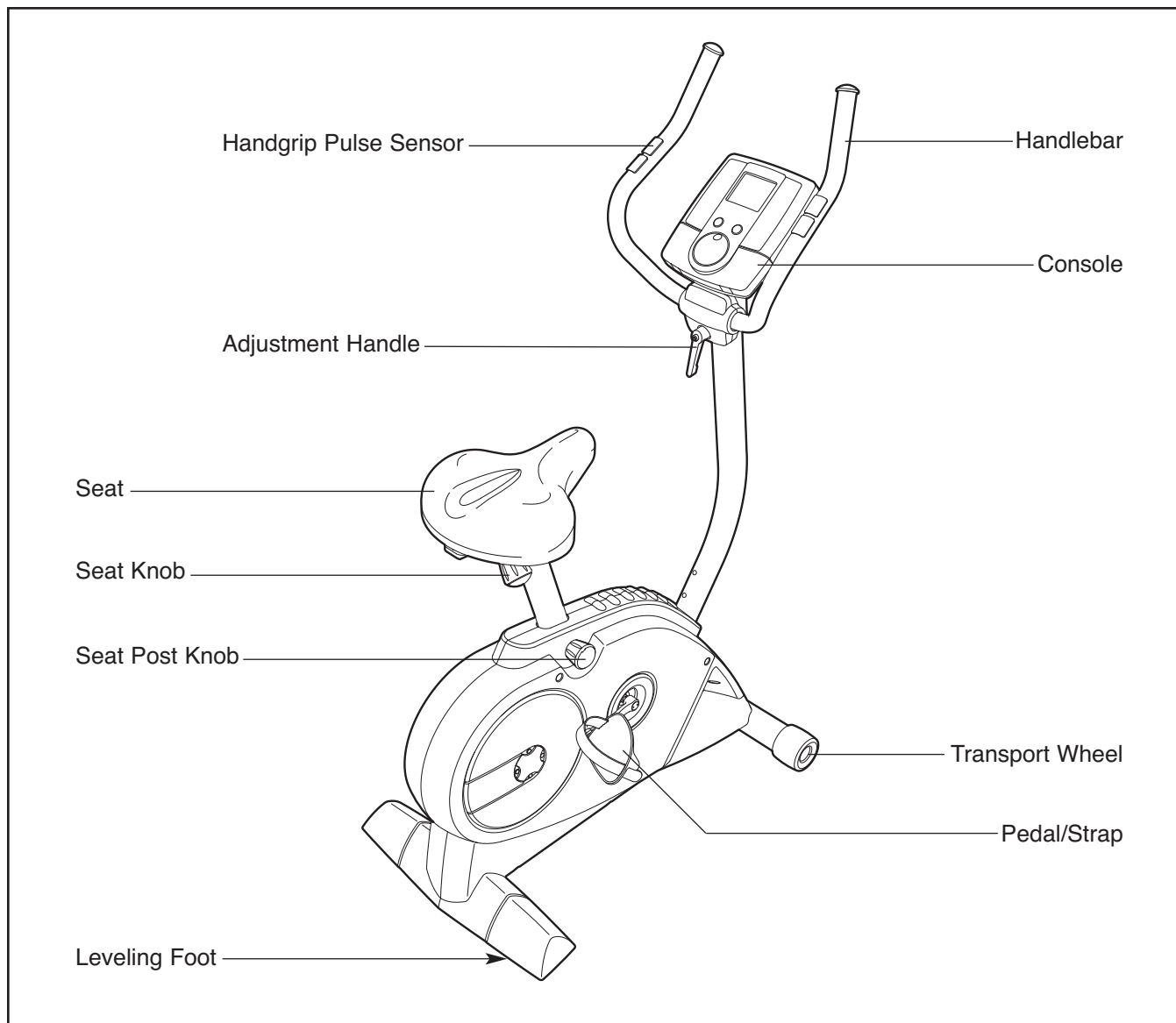

ASSEMBLY

Assembly requires two persons. Place all parts of the exercise cycle in a cleared area and remove the packing materials. Do not dispose of the packing materials until assembly is completed.

In addition to the included tool(s), assembly requires an adjustable wrench  and a Phillips screwdriver .

Use the part drawings below to identify the small parts used in assembly. The number in parentheses below each drawing refers to the key number of the part, from the PART LIST near the end of this manual. The number following the parentheses is the quantity needed for assembly. **Note: Some small parts may have been pre-assembled. If a part is not in the hardware kit, check to see if it has been preassembled.**

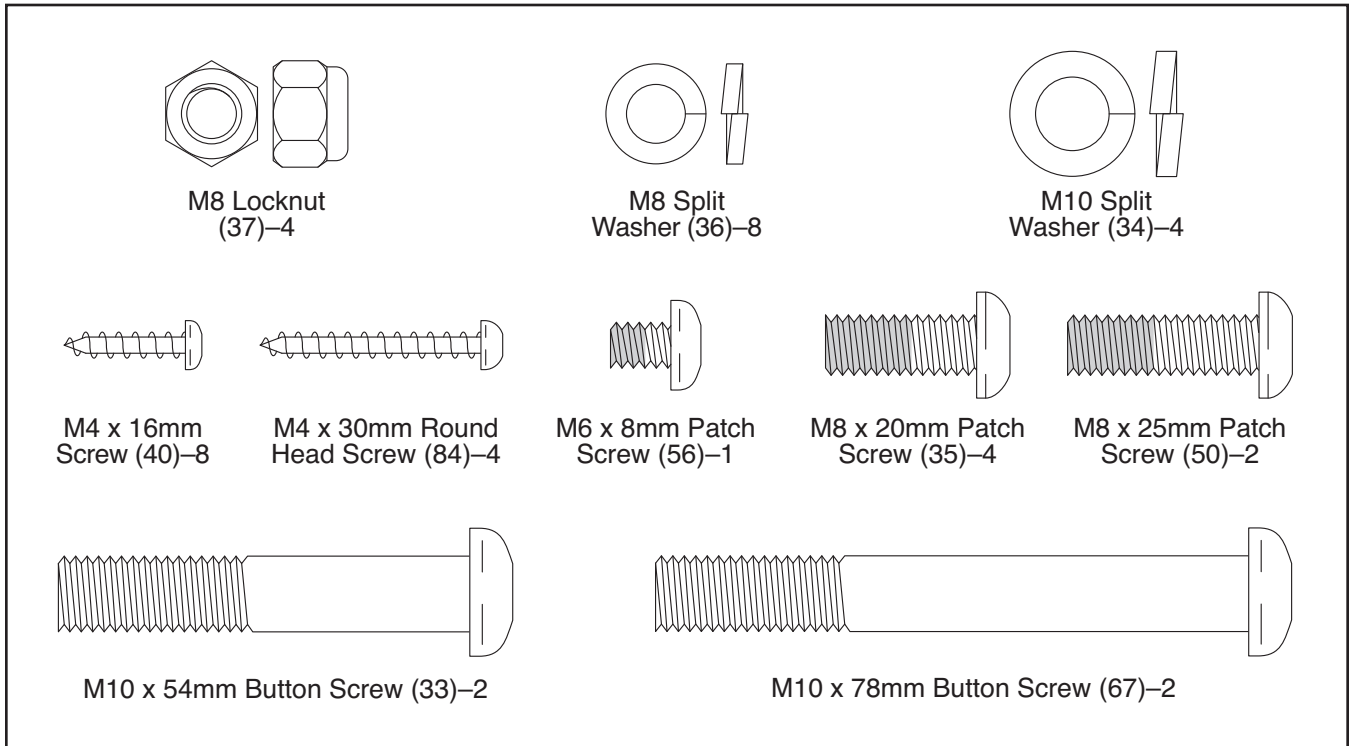

1. **To make assembly easier, read the information on page 5 before you begin assembling the exercise cycle.**

Orient the Rear Stabilizer (14) so that the indicated holes are in the indicated locations.

While another person lifts the rear of the Frame (1), attach the Rear Stabilizer (14) to the Frame with two M10 x 54mm Button Screws (33) and two M10 Split Washers (34).

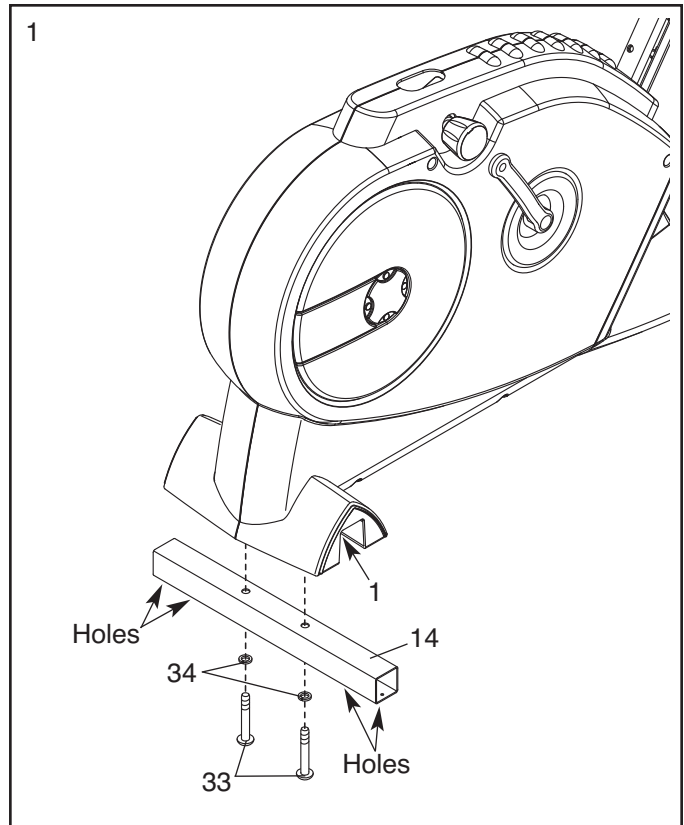

2. Identify the Right Cap (77), which is marked with a "Right" sticker.

Slide the Right Cap (77) onto the right side of the Rear Stabilizer (14). Attach the Right Cap with two M4 x 16mm Screws (40).

Attach the Left Cap (4) in the same way.

Then, tighten the two Leveling Feet (63) into the underside of the Rear Stabilizer (14).

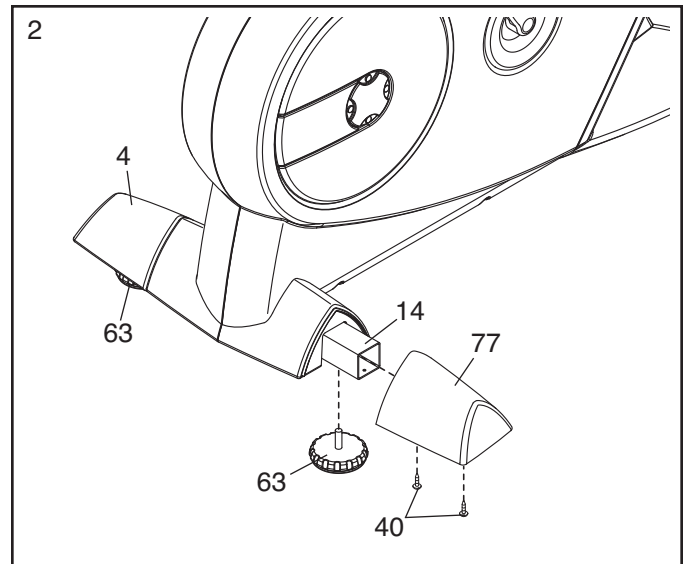

3. While another person lifts the front of the Frame (1), attach the Front Stabilizer (2) to the Frame with two M10 x 78mm Button Screws (67) and two M10 Split Washers (34).

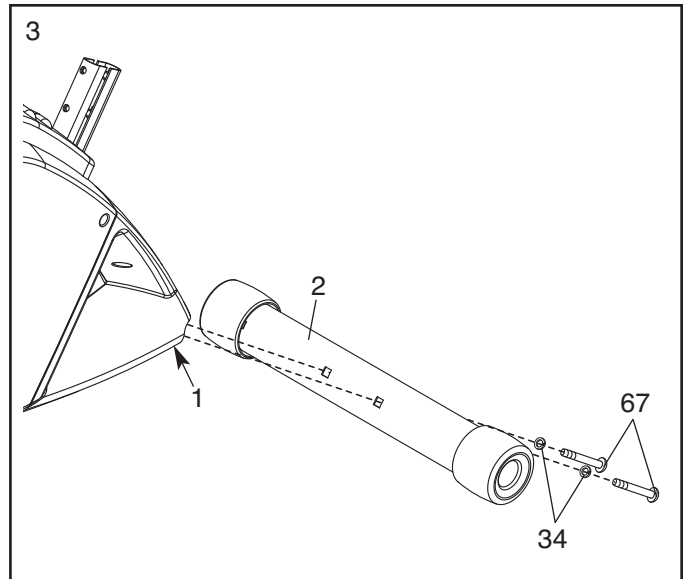

4. While another person holds the Upright (3) near the Frame (1), connect the Upper Wire Harness (32) to the Lower Wire Harness (31).

Gently pull the upper end of the Upper Wire Harness (32) to remove the slack, and slide the Upright (3) onto the Frame (1).

Tip: Avoid pinching the wire harnesses.
Attach the Upright (3) with four M8 x 20mm Patch Screws (35) and four M8 Split Washers (36).

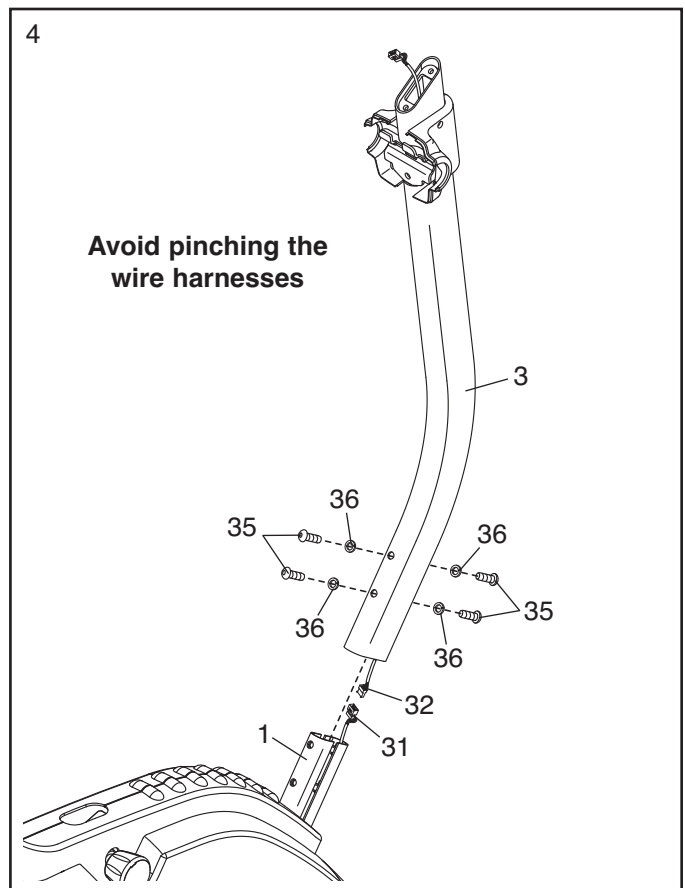

5. While a second person holds the Handlebar (47) near the Upright (3), locate the wire tie in the Upright.

See the inset drawing. Tie the lower end of the wire tie to the Pulse Wires (82). Next, pull the other end of the wire tie upward out of the top of the Upright (3). Then, untie and discard the wire tie. **Tip: Do not allow the ends of the Pulse Wires to fall into the Upright. Use a piece of tape or an elastic band to hold the Pulse Wires in place until step 7.**

Tip: Avoid pinching the Pulse Wires (82).

Attach the Handlebar (47) to the Upright (3) with the Pivot Clamp (75), the Handlebar Cover (43), and the Pivot Handle (72).

Note: The Pivot Handle (72) functions like a ratchet. Turn the Pivot Handle clockwise, pull it away from the Upright (3), turn it counterclockwise, push it toward the Upright, and then turn it clockwise again. Repeat this process until the Pivot Handle is tight.

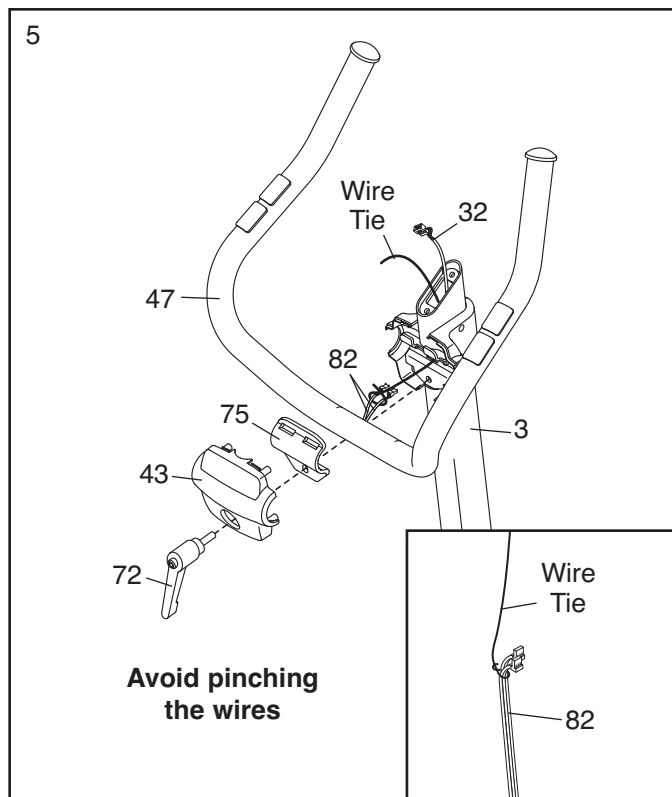

6. Attach the Handlebar Cover (43) to the Left and Right Handlebar Covers (48, 49) with four M4 x 30mm Round Head Screws (84).

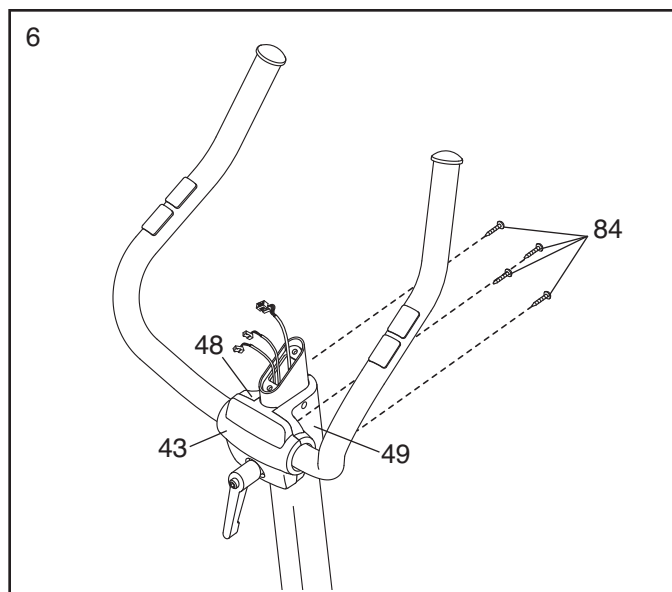

7. Hold the Console Bracket (55) near the Upright (3) as shown, and insert the Upper Wire Harness (32) and the Pulse Wires (82) upward through the hole in the Console Bracket.

Attach the Console Bracket (55) to the Upright (3) with two M8 x 25mm Patch Screws (50).

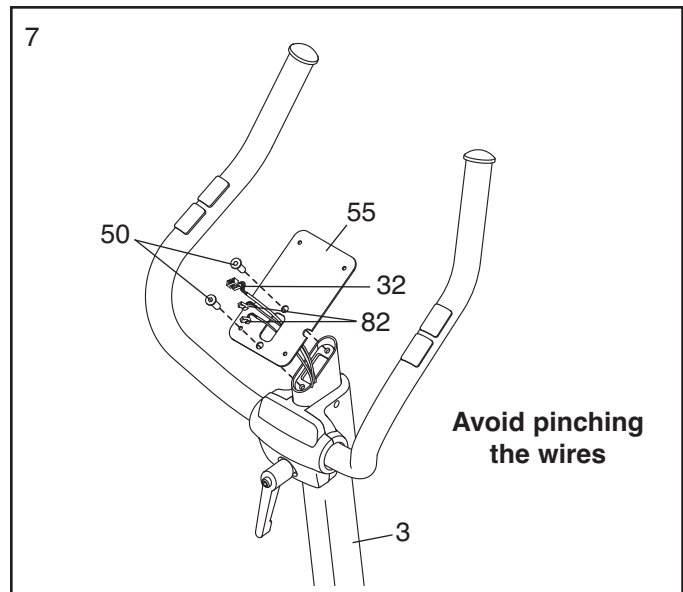

8. The Console (6) requires four D batteries (not included); alkaline batteries are recommended. **IMPORTANT: If the exercise cycle has been exposed to cold temperatures, allow it to warm to room temperature before inserting batteries into the Console. If you do not do this, the console displays or other electronic components may become damaged.** Press the tabs on the battery cover and remove the battery cover. Insert four batteries into the console; **make sure that the batteries are oriented as shown by the markings inside the battery compartments.** Then, reattach the battery cover.

To purchase an optional AC adapter, contact the store where you purchased this product or call the telephone number on the cover of this manual. To avoid damaging the console, use only a manufacturer-supplied AC adapter. Plug one end of the AC adapter into the jack on the console; plug the other end into an outlet installed in accordance with all local codes and ordinances.

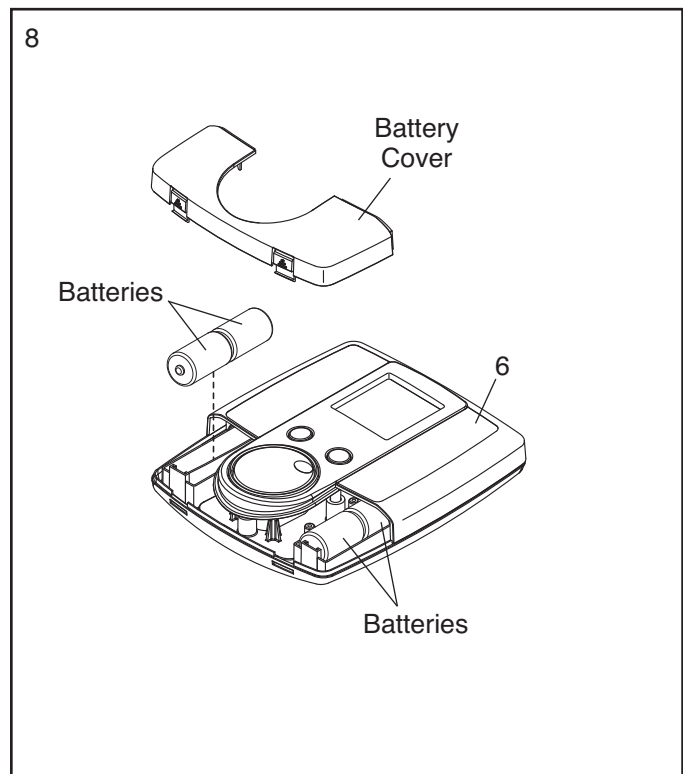

9. While another person holds the Console (6) near the Console Bracket (55), connect the console wire to the Upper Wire Harness (32). Then, connect the console pulse wires to the Pulse Wires (82).

Insert the excess wires downward into the Upright (3).

Tip: Avoid pinching the wires. Attach the Console (6) to the Console Bracket (55) with four M4 x 16mm Screws (40).

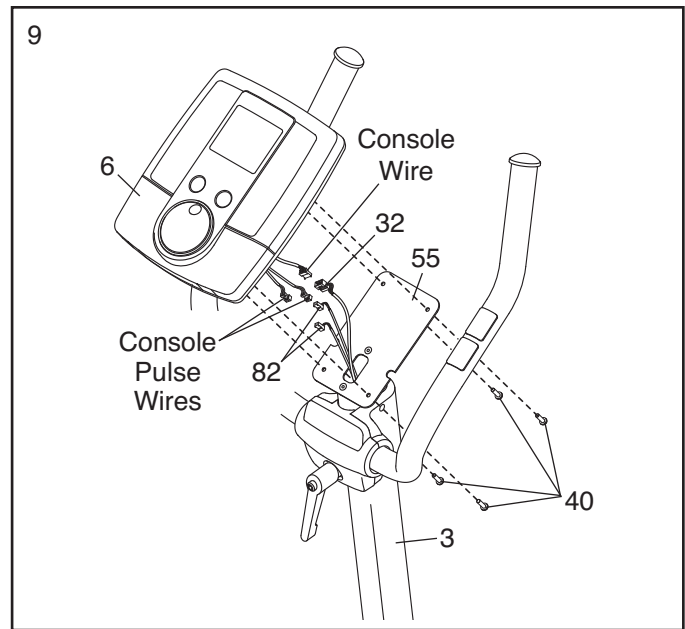

10. Orient the Seat Post (5) as shown.

Loosen the Seat Post Knob (30) a few turns. Next, pull the Seat Post Knob outward, insert the Seat Post into the Frame (1), and then release the Seat Post Knob into one of the holes in the Seat Post. **Move the Seat Post upward and downward slightly to make sure that the pin on the Seat Post Knob is engaged in one of the adjustment holes in the Seat Post.**

Then, tighten the Seat Post Knob (30).

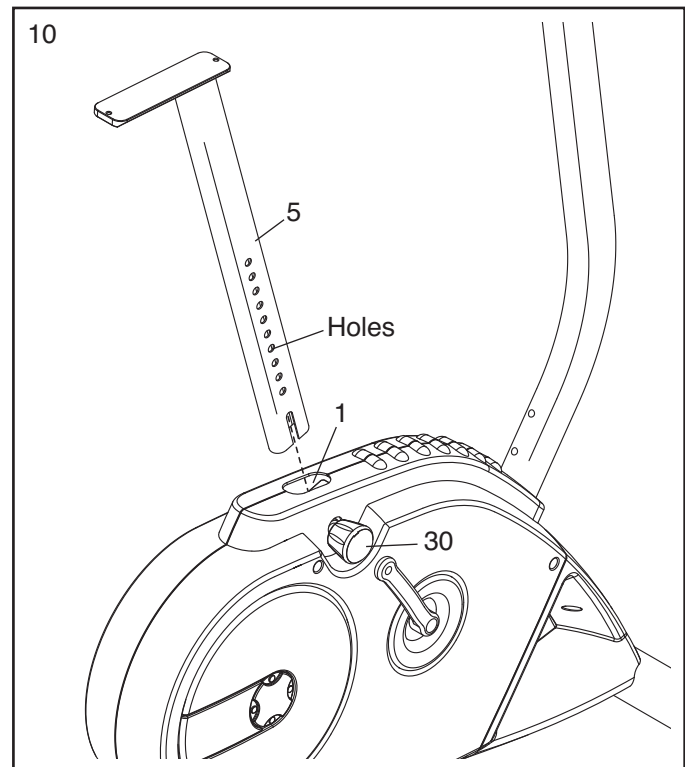

11. Orient the Seat (12) and the Seat Carriage (29) as shown.

Attach the Seat (12) to the Seat Carriage (29) with four M8 Locknuts (37) and four M8 Split Washers (36).

Loosen the Seat Knob (11) and slide the Seat Carriage (29) onto the Seat Post (5) until it stops.

Next, attach an M6 x 8mm Patch Screw (56) to the Seat Post (5). Then, adjust the Seat Carriage (29) to the desired position and tighten the Seat Knob (11).

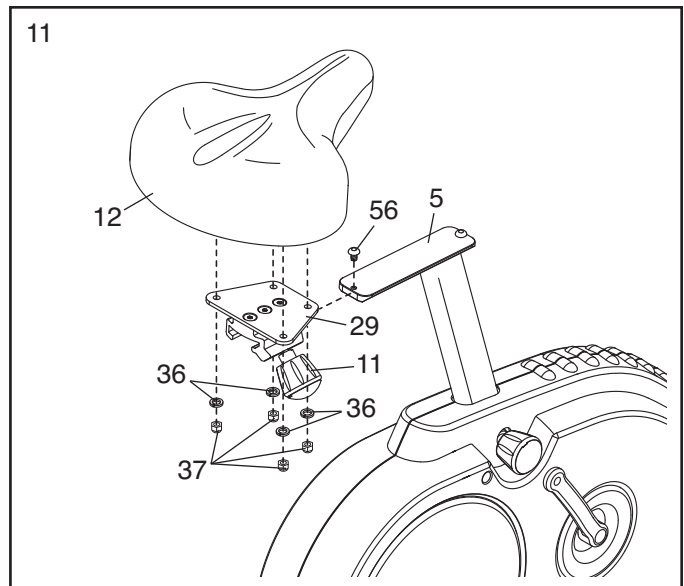

12. Identify the Right Pedal (26), which is marked with an "R." Using an adjustable wrench, **firmly tighten** the Right Pedal *clockwise* into the Right Crank Arm (54).

Tighten the Left Pedal (not shown) *counter-clockwise* into the Left Crank Arm (not shown). **IMPORTANT: Tighten both Pedals as firmly as possible. After using the exercise cycle for one week, retighten the Pedals. For best performance, keep the Pedals tightened.**

Adjust the strap on the Right Pedal (26) to the desired position, and press the end of the strap onto the tab on the side of the Right Pedal.

Adjust the strap on the Left Pedal (not shown) in the same way.

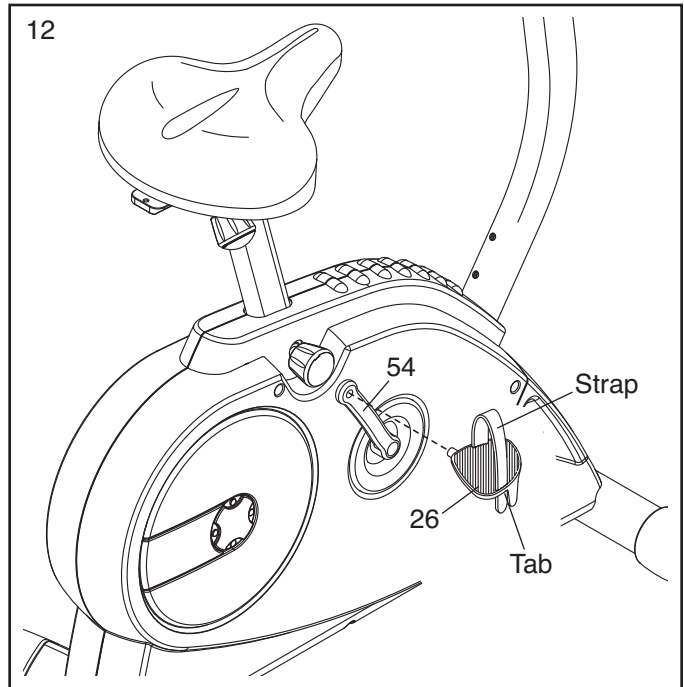

13. **Make sure that all parts are properly tightened before you use the exercise cycle.** Note: After assembly is completed, some extra parts may be left over. Place a mat beneath the exercise cycle to protect the floor.

HOW TO OPERATE THE EXERCISE CYCLE

HOW TO ADJUST THE HEIGHT OF THE SEAT

For effective exercise, the seat should be at the proper height. As you pedal, there should be a slight bend in your knees when the pedals are in the lowest position. To adjust the height of the seat, first loosen the seat post knob.

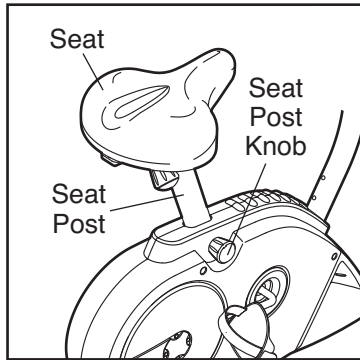

Next, pull the knob, slide the seat post upward or downward to the desired position, and then release the knob. **Move the seat post upward or downward slightly to make sure that the knob is engaged in one of the adjustment holes in the seat post.** Then, tighten the knob.

HOW TO ADJUST THE LATERAL POSITION OF THE SEAT

To adjust the lateral position of the seat, first loosen the seat knob a few turns. Then, move the seat forward or backward to the desired position, and firmly tighten the seat knob.

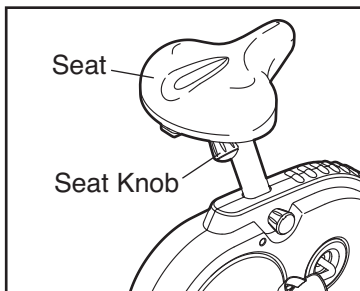

HOW TO ADJUST THE PEDAL STRAPS

To adjust the pedal straps, first pull the ends of the pedal straps off the tabs on the pedals. Adjust the pedal straps to the desired position, and then press the ends of the pedal straps onto the tabs.

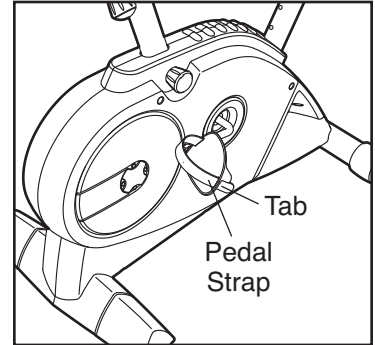

HOW TO ADJUST THE ANGLE OF THE HANDLEBAR

To adjust the angle of the handlebar, loosen the pivot handle, rotate the handlebar to the desired angle, and then retighten the pivot handle. Note: The pivot handle functions like a ratchet. Turn the pivot handle clockwise, pull it

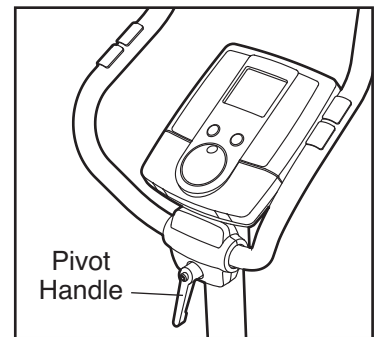

away from the upright, turn it counterclockwise, push it toward the upright, and then turn it clockwise again. Repeat this process until the pivot handle is tight.

CONSOLE DIAGRAM

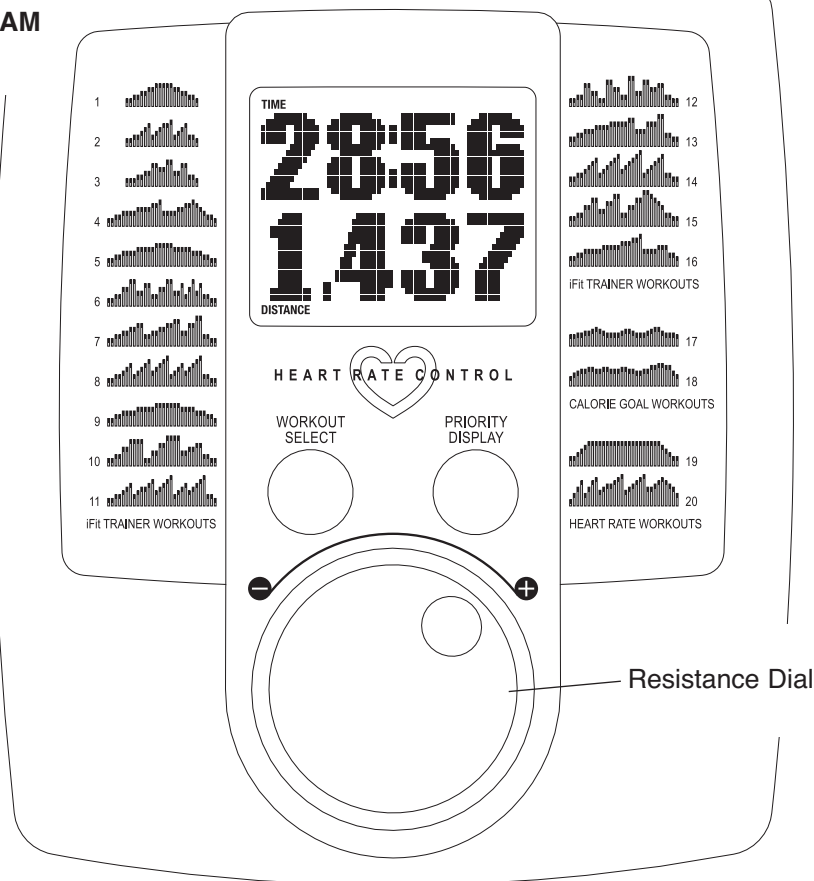

FEATURES OF THE CONSOLE

The advanced console offers an array of features designed to make your workouts more effective and enjoyable. When you select the manual mode of the console, you can change the resistance of the pedals with a touch of the dial. As you exercise, the console will provide continuous exercise feedback. You can even measure your heart rate using the handgrip pulse sensor.

The console offers sixteen trainer workouts. Each workout automatically changes the resistance of the pedals and prompts you to increase or decrease your pedaling pace as it guides you through an effective workout.

You can also use two calorie goal workouts designed to help you burn 150 or 200 calories. The calorie goal workouts automatically control the resistance of the pedals and prompt you to increase or decrease your pedaling pace while counting the calories you burn.

In addition, the console offers two heart rate workouts that change the resistance of the pedals to keep your heart rate near a target heart rate while you exercise.

IMPORTANT: Before you use the console for the first time, you must select BIKE or ELLIPTICAL; if you do not do this, the console will not display correct feedback. (See HOW TO ENTER CONSOLE SETTINGS on page 14.)

To enter console settings, see page 14. To use the manual mode, see page 15. To use a trainer workout, see page 17. To use a calorie goal workout, see page 18. To use a heart rate workout, see page 19.

Note: If there is a sheet of clear plastic on the face of the console, remove the plastic.

HOW TO ENTER CONSOLE SETTINGS

1. **Begin pedaling or press any button on the console to turn on the console.**

A moment after you begin pedaling or press a button, the display will light.

2. **Select the user mode.**

The user mode allows you to select the type of product that the console is operating, select a unit of measurement for an exercise cycle, and select a backlight option for the console.

To select the user mode, press and hold the Workout Select button for several seconds until the words BIKE and ELLIPTICAL appear in the display.

3. **Select BIKE or ELLIPTICAL as the product type.**

The arrow in the display indicates the currently selected product type. To change the selection, press the Priority Display button repeatedly.

If the console is operating an exercise cycle, select BIKE as the product type. **If the console is operating an elliptical exerciser,** select ELLIPTICAL as the product type.



Then, press the Workout Select button to save your selection. The other console settings will then appear in the display.

IMPORTANT: If you selected **BIKE**, go to step 4. If you selected **ELLIPTICAL**, go to step 5.

4. **If the console is operating an exercise cycle, select a unit of measurement.**

When the console operates an exercise cycle, the console can show speed and distance in either miles or kilometers.

If you selected BIKE as the product type, the word ENGLISH (for English miles) or the word METRIC (for metric kilometers) will appear in the display to show which unit of measurement is selected.



To change the unit of measurement, turn the resistance dial until the desired unit of measurement appears in the display.

5. **Select a backlight option, if desired.**

The console has three backlight options. The ON option keeps the backlight on while the console is on. The AUTO option keeps the backlight on only while you are pedaling. The OFF option turns the backlight off.

To select a backlight option, press the Priority Display button repeatedly until the desired backlight option appears in the display.

6. **Exit the user mode.**

Press the Workout Select button to save the console settings and exit the user mode.

HOW TO USE THE MANUAL MODE

1. **Begin pedaling or press any button on the console to turn on the console.**

A moment after you begin pedaling or press a button, the display will light.

2. **Select the manual mode.**

Each time you turn on the console, the manual mode will be selected. If you have selected a workout, reselect the manual mode by pressing the Workout button repeatedly until the word MANUAL appears in the lower left corner of the display.



3. **Begin pedaling and change the resistance of the pedals as desired.**

As you pedal, change the resistance of the pedals by turning the resistance dial. To increase the resistance, turn the resistance dial clockwise; to decrease the resistance, turn the resistance dial counterclockwise. Note: After you change the resistance, it will take a moment for the pedals to reach the selected resistance level.

4. **Follow your progress with the display.**

The upper left corner of the display will show the elapsed time. Note: When a workout is selected, the display will show the time remaining in the workout instead of the elapsed time.

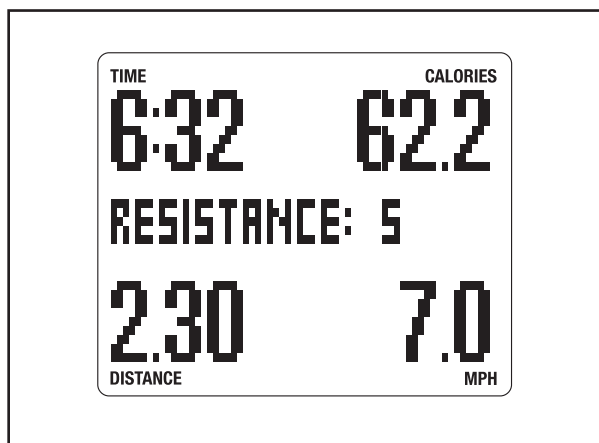

The lower left corner of the display will show the distance you have pedaled.

Note: If the console is operating an exercise cycle, the distance will be shown in miles or kilometers. If the console is operating an elliptical exerciser, the distance will be shown in total number of revolutions.

The upper right corner of the display will show the approximate number of calories you have burned. The upper right corner of the display will also show your heart rate when you use the hand-grip pulse sensor (see step 5 on page 16).

Note: When a calorie goal workout is selected, the display will count down the approximate number of calories that have been burned.

The lower right corner of the display will show your pedaling pace.

Note: If the console is operating an exercise cycle, your pedaling pace will be shown in miles per hour or kilometers per hour. If the console is operating an elliptical exerciser, your pedaling pace will be shown in revolutions per minute (rpm).

The center of the display will show the resistance level of the pedals for a few seconds each time the resistance level changes.

You can also view selected information at a larger size. Press the Priority Display button repeatedly to view time and distance information, time and calorie information, or time and pace information. Press the Priority Display button again to view all information.

5. Measure your heart rate if desired.

If there are sheets of clear plastic on the metal contacts on the handgrip pulse sensor, remove the plastic. To measure your heart rate, hold the handgrip pulse sensor with your palms resting against the metal contacts. **Avoid moving your hands or gripping the contacts too tightly.**

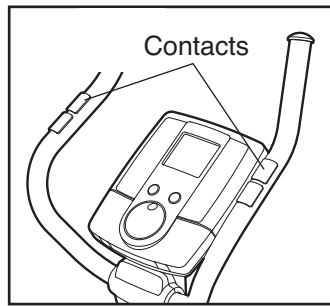

When your pulse is detected, one, two, or three dashes will appear in the display, and then your heart rate will be shown. For the most accurate heart rate reading, hold the contacts for at least 15 seconds. Note: If you continue to hold the handgrip pulse sensor, the display will show your heart rate for up to 30 seconds.

If the display does not show your heart rate, make sure that your hands are positioned as described. Be careful not to move your hands excessively or to squeeze the metal contacts too tightly. For optimal performance, clean the metal contacts using a soft cloth; **never use alcohol, abrasives, or chemicals to clean the contacts.**

6. When you are finished exercising, the console will turn off automatically.

If the pedals do not move for several seconds, a tone will sound and the console will pause. If the pedals do not move for several minutes and the buttons are not pressed, the console will turn off and the display will be reset.

HOW TO USE A TRAINER WORKOUT

1. Begin pedaling or press any button on the console to turn on the console.

A moment after you begin pedaling or press a button, the display will light.

2. Select a trainer workout.

To select a trainer workout, press the Workout Select button repeatedly until the number of the desired workout appears in the display. The workout time and a profile of the resistance levels for the workout will also appear in the display.

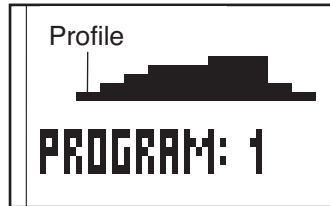

Note: The number and profile of each trainer workout is printed on the console.

3. Begin pedaling to start the workout.

Each workout is divided into several one-minute segments. One resistance level and one target pace (rpm) are programmed for each segment. Note: The same resistance level and/or target pace may be programmed for consecutive segments.

The workout profile will show your progress (see the drawing above). The flashing segment of the profile represents the current segment of the workout. The height of the flashing segment indicates the resistance level for the current segment.

When the first segment of the workout ends, the resistance level and the target pace for the second segment will appear in the center of the display for a few seconds to alert you. The next segment of the profile will begin to flash, and the pedals will automatically adjust to the resistance level for the next segment.

As you exercise, you will be prompted to keep your pedaling pace near the target pace for the current segment. When an upward arrow appears in the display, increase your pace. When a downward arrow appears, decrease your pace. When no arrow appears, maintain your current pace.

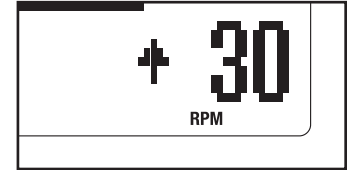

IMPORTANT: The target pace is intended only to provide motivation. Your actual pace may be slower than the target pace. Make sure to pedal at a pace that is comfortable for you.

If the resistance level for the current segment is too high or too low, you can manually override the setting by turning the resistance dial. **IMPORTANT: When the current segment of the workout ends, the pedals will automatically adjust to the resistance level for the next segment.**

The workout will continue in this way until the last segment ends. To stop the workout at any time, stop pedaling. A tone will sound and the time will begin to flash in the display. To restart the workout, simply resume pedaling.

4. Follow your progress with the display.

See step 4 on page 15.

5. Measure your heart rate if desired.

See step 5 on page 16.

6. When you are finished exercising, the console will turn off automatically.

See step 6 on page 16.

HOW TO USE A CALORIE GOAL WORKOUT

1. Begin pedaling or press any button on the console to turn on the console.

A moment after you begin pedaling or press a button, the display will light.

2. Select a calorie goal workout.

Press the Workout Select button repeatedly until the number of the desired calorie goal workout appears in the display. The workout time, the number of calories to be burned, and a profile of the resistance levels for the workout will also appear in the display.

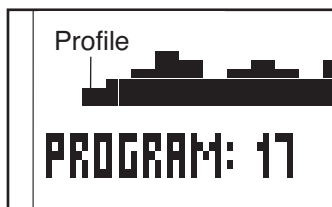

Note: The number and profile of each calorie goal workout is printed on the console.

3. Begin pedaling to start the workout.

Each calorie goal workout will help you burn 150 or 200 calories. During each workout, the console will count down the number of calories to be burned.

Each calorie goal workout is divided into 30 one-minute segments. One resistance level and one target pace (rpm) are programmed for each segment of the workout. Note: The same resistance level and/or target pace may be programmed for consecutive segments.

The workout profile will show your progress (see the drawing above). The flashing segment of the profile represents the current segment of the workout. The height of the flashing segment indicates the resistance level for the current segment.

When the first segment of the workout ends, the resistance level and the target pace for the second segment will appear in the center of the display for a few seconds to alert you. The next segment of the profile will begin to flash, and the pedals will automatically adjust to the resistance level for the next segment.

As you exercise, you will be prompted to keep your pedaling pace near the target pace for the current segment. When an upward arrow appears in the display, increase your pace. When a downward arrow appears, decrease your pace. When no arrow appears, maintain your current pace.

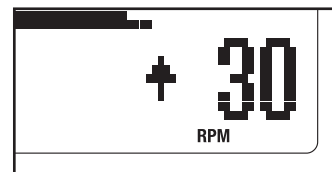

IMPORTANT: The target pace is intended only to provide motivation. Your actual pace may be slower than the target pace. Make sure to pedal at a pace that is comfortable for you.

If the resistance level for the current segment is too high or too low, you can manually override the setting by turning the resistance dial. **IMPORTANT: When the current segment of the workout ends, the pedals will automatically adjust to the resistance level for the next segment.**

The workout will continue in this way until the last segment ends. To stop the workout at any time, stop pedaling. A tone will sound and the time will begin to flash in the display. To restart the workout, simply resume pedaling.

4. Follow your progress with the display.

See step 4 on page 15.

5. Measure your heart rate if desired.

See step 5 on page 16.

6. When you are finished exercising, the console will turn off automatically.

See step 6 on page 16.

HOW TO USE A HEART RATE WORKOUT

1. Begin pedaling or press any button on the console to turn on the console.

A moment after you begin pedaling or press a button, the display will light.

2. Select a heart rate workout.

Press the Workout Select button repeatedly until the number of the desired heart rate workout appears in the display. The workout time and a profile of the resistance levels for the workout will also appear in the display.

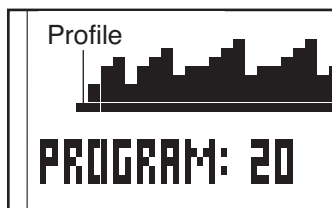

Note: The number and profile of each heart rate workout is printed on the console.

3. Enter a target heart rate setting.

A few seconds after you select a heart rate workout, the words ADJUST MAX TARGET HEART RATE will appear in the display and the number 110 will begin to flash.

Different target heart rate settings will be programmed for different segments of the heart rate workout. Turn the resistance dial to enter the desired maximum target heart rate for the workout (see EXERCISE INTENSITY on page 21).

4. Hold the handgrip pulse sensor.

It is not necessary to hold the handgrip pulse sensor continuously during heart rate workouts; however, you should hold the handgrip pulse sensor frequently for the workouts to operate properly.

Each time you hold the handgrip pulse sensor, keep your hands on the metal contacts for at least 30 seconds.

5. Begin pedaling to start the workout.

Each heart rate workout is divided into 30 one-minute segments. One target heart rate is programmed for each segment. Note: The same target heart rate may be programmed for consecutive segments.

During the workout, the workout profile in the display will show your progress. The flashing segment of the profile represents the current segment of the workout. The height of the flashing segment indicates the target heart rate for the current segment. At the end of each segment of the workout, a series of tones will sound and the next segment of the profile will begin to flash.

The console will regularly compare your heart rate to the target heart rate for the current segment of the workout. If your heart rate is too far below or above the target heart rate, the resistance of the pedals will automatically increase or decrease to bring your heart rate closer to the target heart rate. Each time the resistance changes, the resistance level will appear in the display for a few seconds to alert you.

As you exercise, you will be prompted to pedal at a steady pace. When an upward arrow appears in the display, increase your pace. When a downward arrow appears, decrease your pace. When no arrow appears, maintain your current pace.

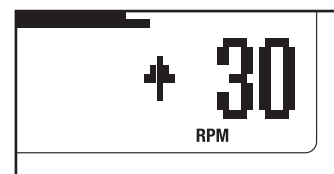

IMPORTANT: Make sure to pedal at a pace that is comfortable for you. Note: If the resistance level for the current segment is too high or too low, you can manually override the setting by turning the resistance dial; however, if you change the resistance level, you might not maintain the target heart rate. Also, when the console compares your heart rate to the target heart rate, the resistance of the pedals may automatically increase or decrease to bring your heart rate closer to the target heart rate.

The workout will continue in this way until the last segment ends. To stop the workout at any time, stop pedaling. A tone will sound and the time will begin to flash in the display. To restart the workout, simply resume pedaling.

6. Follow your progress with the display.

See step 4 on page 15.

7. When you are finished exercising, the console will turn off automatically.

See step 6 on page 16.

MAINTENANCE AND TROUBLESHOOTING

Inspect and properly tighten all parts of the exercise cycle regularly. Replace any worn parts immediately. To clean the exercise cycle, use a damp cloth and a small amount of mild soap—**never use alcohol, abrasives, or chemicals to clean the exercise cycle.**

IMPORTANT: To avoid damage to the console, keep liquids away from the console and keep the console out of direct sunlight.

CONSOLE TROUBLESHOOTING

If the console display becomes dim, the batteries should be replaced; most console problems are the result of low batteries. To replace the batteries, see assembly step 8 on page 9. If the console does not display your heart rate when you use the handgrip pulse sensor, see step 5 on page 16.

HOW TO ADJUST THE REED SWITCH

If the console does not display correct feedback, the reed switch should be adjusted. To adjust the reed switch, you must first remove the left pedal and the left shield. Using an adjustable wrench, turn the left pedal clockwise and remove it. Next, remove the screws from the left and right shields; **there are three sizes of screws in the shields—note which size of screw you remove from each hole.** Then, gently remove the left shield.

Locate the Reed Switch (21). Turn the Right Crank Arm (54) until a Magnet (16) is aligned with the Reed Switch. Next, loosen, but do not remove, the indicated M4 x 16mm Flange Screw (61). Slide the Reed Switch slightly closer to or away from the Magnet, and then retighten the Flange Screw. Turn the Right Crank Arm Crank for a moment. Repeat these actions until the console displays correct feedback. When the Reed Switch is correctly adjusted, reattach the left shield and the left pedal.

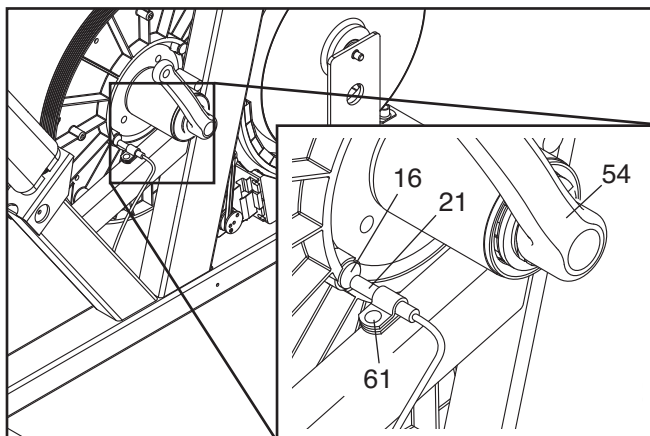

HOW TO ADJUST THE BELT

If you can feel the pedals slip while you are pedaling, even when the resistance is at the highest level, the belt may need to be adjusted.

To adjust the belt, you must first remove the right pedal and the right shield. Using an adjustable wrench, turn the right pedal clockwise and remove it. Next, remove the screws from the left and right shields; **there are three sizes of screws in the shields—note which size of screw you remove from each hole.** Then, gently remove the right shield.

To tighten the belt, first loosen the M10 x 22mm Bolt (45). Next, tighten the M8 x 38mm Hex Screw (69) until the belt is tight. Then, retighten the M10 x 22mm Bolt (45). Reattach the right shield and the right pedal.

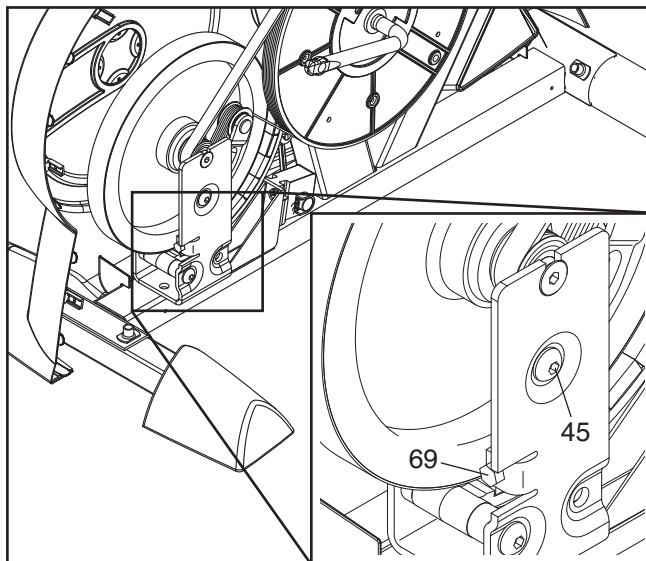

EXERCISE GUIDELINES

⚠ WARNING: Before beginning this or any exercise program, consult your physician. This is especially important for persons over the age of 35 or persons with pre-existing health problems.

The pulse sensor is not a medical device. Various factors may affect the accuracy of heart rate readings. The pulse sensor is intended only as an exercise aid in determining heart rate trends in general.

These guidelines will help you to plan your exercise program. For detailed exercise information, obtain a reputable book or consult your physician. Remember, proper nutrition and adequate rest are essential for successful results.

EXERCISE INTENSITY

Whether your goal is to burn fat or to strengthen your cardiovascular system, exercising at the proper intensity is the key to achieving results. You can use your heart rate as a guide to find the proper intensity level. The chart below shows recommended heart rates for fat burning and aerobic exercise.

165	155	145	140	130	125	115	♥
145	138	130	125	118	110	103	♥
125	120	115	110	105	95	90	♥
<hr/>							
20	30	40	50	60	70	80	

To find the proper intensity level, find your age at the bottom of the chart (ages are rounded off to the nearest ten years). The three numbers listed above your age define your “training zone.” The lowest number is the heart rate for fat burning, the middle number is the heart rate for maximum fat burning, and the highest number is the heart rate for aerobic exercise.

Burning Fat—To burn fat effectively, you must exercise at a low intensity level for a sustained period of time. During the first few minutes of exercise, your body uses *carbohydrate calories* for energy. Only after the first few minutes of exercise does your body begin to use stored *fat calories* for energy. If your goal is to burn fat, adjust the intensity of your exercise until your heart rate is near the lowest number in your training zone. For maximum fat burning, exercise with your heart rate near the middle number in your training zone.

Aerobic Exercise—If your goal is to strengthen your cardiovascular system, you must perform aerobic exercise, which is activity that requires large amounts of oxygen for prolonged periods of time. For aerobic exercise, adjust the intensity of your exercise until your heart rate is near the highest number in your training zone.

WORKOUT GUIDELINES

Warming Up—Start with 5 to 10 minutes of stretching and light exercise. A warm-up increases your body temperature, heart rate, and circulation in preparation for exercise.

Training Zone Exercise—Exercise for 20 to 30 minutes with your heart rate in your training zone. (During the first few weeks of your exercise program, do not keep your heart rate in your training zone for longer than 20 minutes.) Breathe regularly and deeply as you exercise—never hold your breath.

Cooling Down—Finish with 5 to 10 minutes of stretching. Stretching increases the flexibility of your muscles and helps to prevent post-exercise problems.

EXERCISE FREQUENCY

To maintain or improve your condition, complete three workouts each week, with at least one day of rest between workouts. After a few months of regular exercise, you may complete up to five workouts each week, if desired. Remember, the key to success is to make exercise a regular and enjoyable part of your everyday life.

PART LIST—Model No. PFEVEX74108.0

R0908A

Key No.	Qty.	Description	Key No.	Qty.	Description
1	1	Frame	45	1	M10 x 22mm Bolt
2	1	Front Stabilizer	46	1	C-magnet
3	1	Upright	47	1	Handlebar
4	1	Left Cap	48	1	Left Handlebar Cover
5	1	Seat Post	49	1	Right Handlebar Cover
6	1	Console	50	2	M8 x 25mm Patch Screw
7	1	Flywheel	51	2	Handlebar Cap
8	1	Resistance Motor	52	1	M10 Locknut
9	4	M4 x 12mm Screw	53	1	Left Crank Arm
10	1	Resistance Arm	54	1	Right Crank Arm
11	1	Seat Knob	55	1	Console Bracket
12	1	Seat	56	2	M6 x 8mm Patch Screw
13	1	Pulley/Crank	57	1	Short C-magnet Spacer
14	1	Rear Stabilizer	58	4	V-clip
15	2	Transport Wheel	59	1	M10 x 82mm Shoulder Bolt
16	2	Magnet	60	1	Resistance Wheel
17	1	Left Shield	61	7	M4 x 16mm Flange Screw
18	1	Right Shield	62	1	M3.5 x 12mm Screw
19	1	Resistance Motor Bracket	63	2	Leveling Foot
20	1	Seat Post Bushing	64	1	M4 x 5mm Screw
21	1	Reed Switch/Wire	65	4	M3.8 x 20mm Round Head Screw
22	2	Clamp	66	2	M8 Washer
23	1	Belt	67	2	M10 x 78mm Button Screw
24	1	Left Pedal/Strap	68	1	M4 x 16mm Bright Screw
25	2	Flywheel Bearing	69	1	M8 x 38mm Hex Screw
26	1	Right Pedal/Strap	70	4	M4 Locknut
27	2	Crank Bearing	71	3	M8 x 20mm Flat Head Screw
28	1	Idler	72	1	Pivot Handle
29	1	Seat Carriage	73	1	Seat Plate
30	1	Seat Post Knob	74	4	Contact
31	1	Lower Wire Harness	75	1	Pivot Clamp
32	1	Upper Wire Harness	76	1	Wire Clamp
33	2	M10 x 54mm Button Screw	77	1	Right Cap
34	4	M10 Split Washer	78	2	Crank Cap
35	4	M8 x 20mm Patch Screw	79	2	Flange Screw
36	8	M8 Split Washer	80	1	Snap Ring
37	7	M8 Locknut	81	4	#3 x 8mm Screw
38	2	M8 x 25mm Shoulder Patch Screw	82	2	Pulse Wire
39	2	M4 x 64mm Screw	83	4	M4 x 16mm Round Head Screw
40	14	M4 x 16mm Screw	84	4	M4 x 30mm Round Head Screw
41	1	M4 x 30mm Screw	85	2	M8 Flat Washer
42	1	Flywheel Axle	*	—	User's Manual
43	1	Handlebar Cover	*	—	Assembly Tool
44	1	Long C-magnet Spacer			

Note: Specifications are subject to change without notice. See the back cover of this manual for information about ordering replacement parts. *These parts are not illustrated.

EXPLODED DRAWING—Model No. PFEVEX74108.0

R0908A

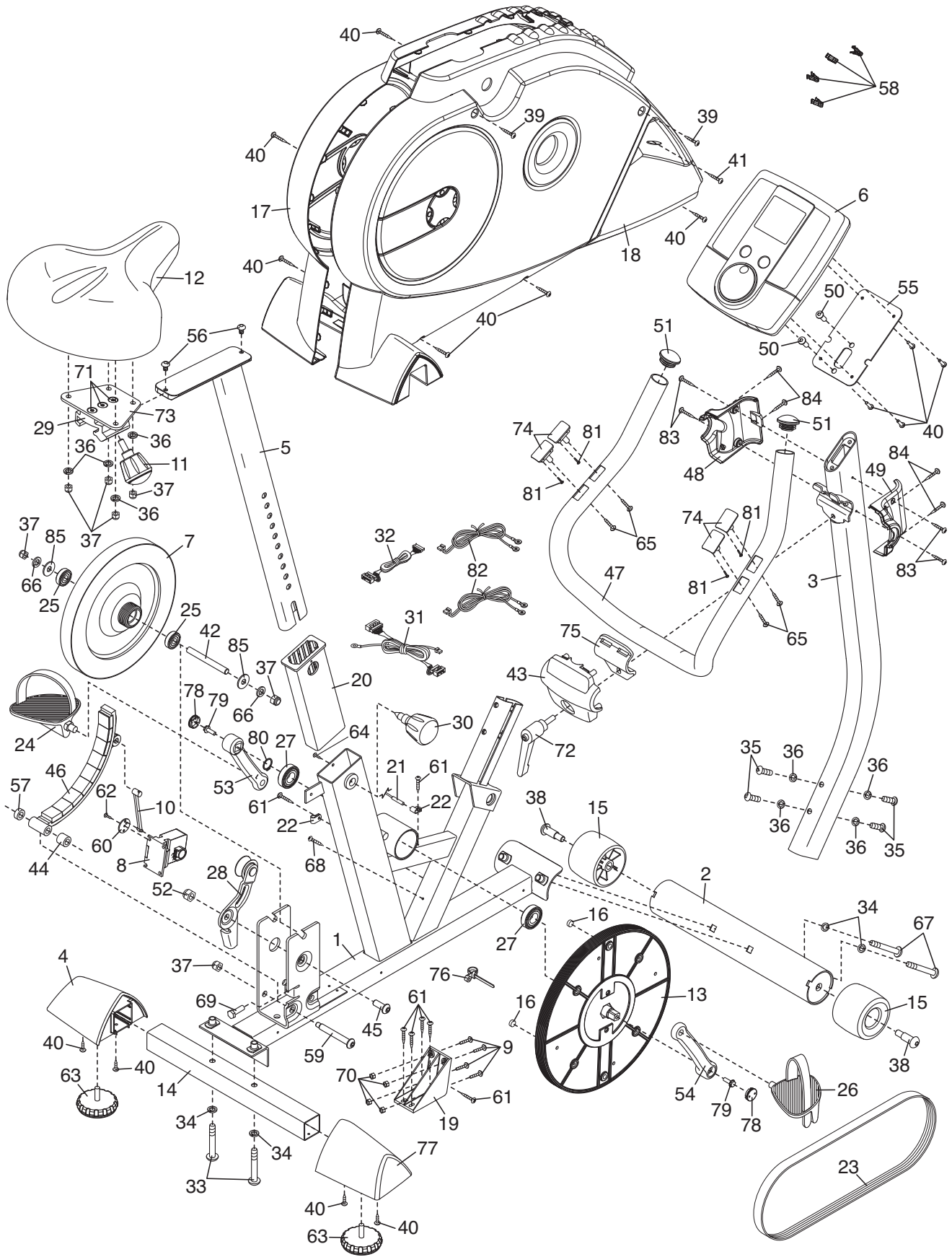

ORDERING REPLACEMENT PARTS

To order replacement parts, please see the front cover of this manual. To help us assist you, be prepared to provide the following information when contacting us:

- the model number and serial number of the product (see the front cover of this manual)
- the name of the product (see the front cover of this manual)
- the key number and description of the replacement part(s) (see the PART LIST and the EXPLODED DRAWING near the end of this manual)