

STRIKER

TABLE FOOTBALL GAME



ASSEMBLY INSTRUCTIONS









Please keep for future reference
Adult Assembly Required

(0316)

ASSEMBLY INSTRUCTIONS

Please keep these instructions for future reference. Adult assembly required.
This table is not a toy & is intended for use by or under the supervision of adults.
Please do not sit, climb or lean on the table.
This table is intended for indoor use only.

Parts Identifier

							
Coach bolt	Screw	Washer	Large nut	Small nut	Flat head bolt	Allen key	Star washer
8pcs	32pcs	8pcs	8pcs	8pcs	8pcs	1pc	8pcs small 8pcs large

1. Find a clean & level place to begin the assembly of your STRIKER table football game. You will need a Phillips screwdriver, a 13mm & a 17mm spanner & a hammer. Remove all parts from the box & save all packing materials until the parts have been inspected & the table is assembled.
2. Attaching the legs – place the table onto the floor facing the correct way up. Open the table, lift the lid & use the metal lid prop provided to keep the top open. Remove the poles, slopes, legs & plastic parts bag from inside the table. Close the table & stand it up on its end so that it can be opened 90 degrees like a book. Important – this should be carried out by 2 adults.
3. Make sure the legs are the correct way round (see below) & then attach the legs into the slots underneath the table using the bolts, washers & nuts provided. Fit the rubber feet to the bottom of each of the 4 legs.

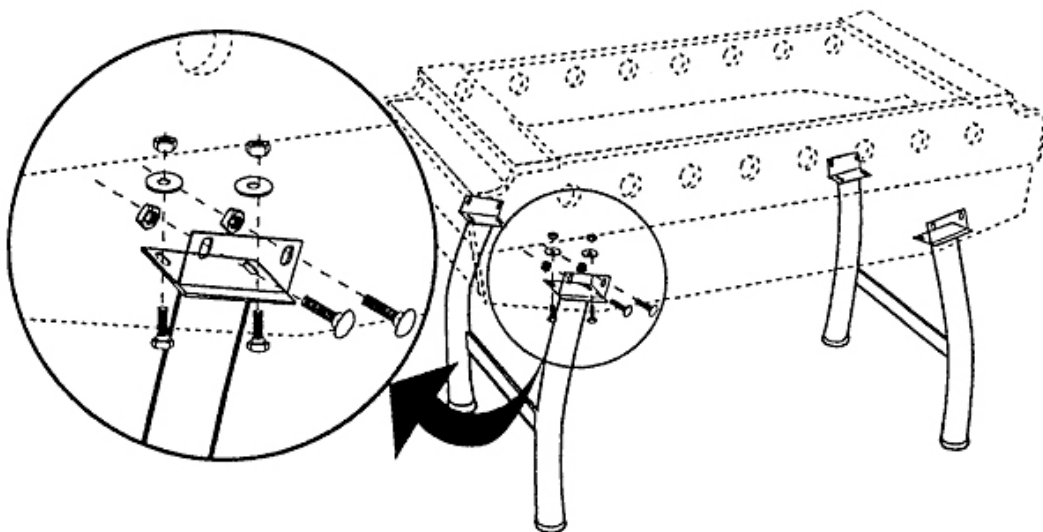

Insert the coach bolts into the sides of the table & secure on the inside with a large star washer & then a large nut. The flat head bolts should be inserted underneath the table & secured on the inside with a washer, then a small star washer & then a small nut. The square neck of the coach bolt will not fit into the round hole. Tighten the nut so that the neck breaks into the laminate but do not over-tighten – this will not cause the laminate to crack. The mushroom head of the coach bolt should just touch the laminate surface.

4. Stand the table up on its legs & prepare to fit the poles. Remove the glass by unscrewing the 3 bolts (use the allen key) at one end of the top. Using gloves to protect your hands, slide out the glass top. This should be carried out by 2 adults for safety's sake.

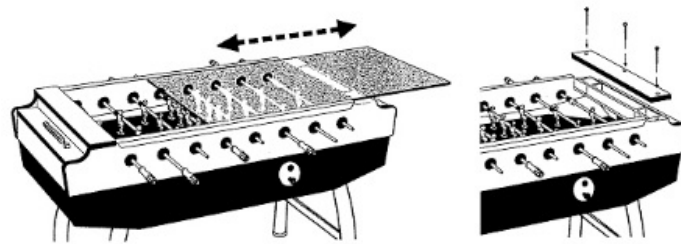

5. Next, slide the thin bars into the thick bars as shown below:

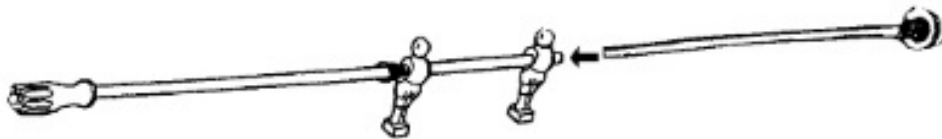

6. Push the bars into the table, pushing the handle-end of the pole through the hole first from the inside. Do not fit the handles onto the poles at this stage.

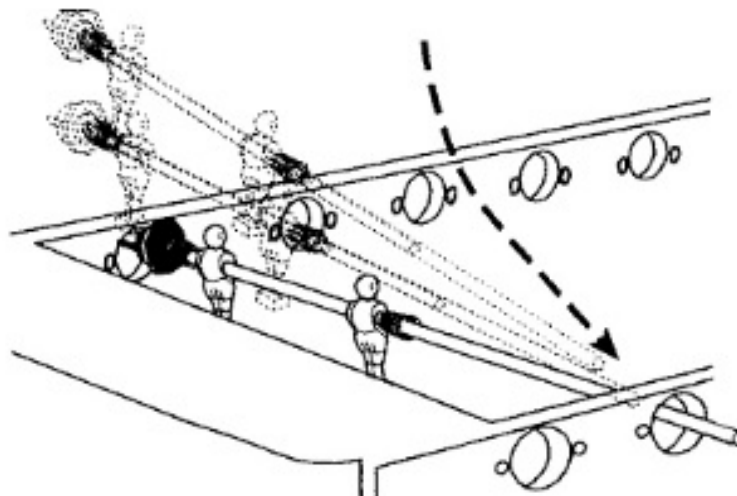

Then starting from the blue score counters end of the table insert the poles as follows:

- Blue 1-man pole
- Blue 2-man pole
- Red 3-man pole
- Blue 5-man pole
- Red 5-man pole
- Blue 3-man pole
- Red 2-man pole
- Red 1-man pole

There should now be 4 poles on each side of the table with the red & blue teams facing each other.

7. Next, put the rubber washers into the 8 flat-end plastic caps. Push the bearing fitted to the thin rod into the hole & fit the flat cap from outside, making sure that the 'legs' on the inside bearing line up with the screw holes on the end cap. Secure with 2 screws but do not over-tighten.

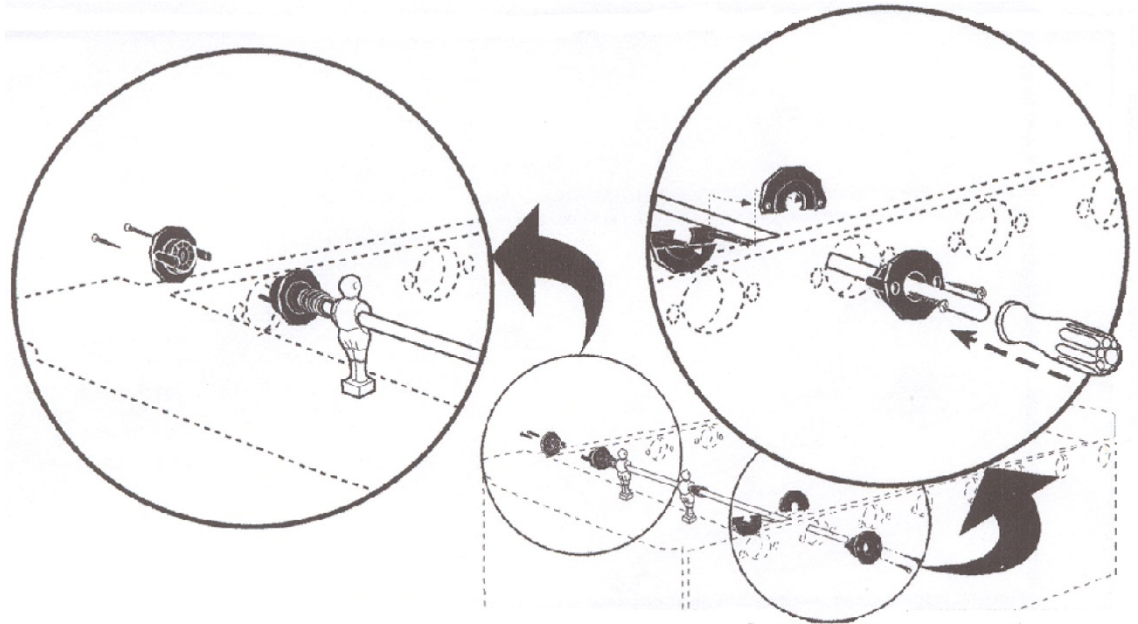

At the handle end of the pole put 2 half-bearings on to the bar from the inside & push into the hole. Then slide the large bearing onto the end of the pole & line up the 'legs' of both the half-bearings & the large bearing. Insert screws & tighten. Finally hammer on the handles to the ends of the poles.

8. Carefully put back the glass top & screw down the flat top ends again using the allen key provided. If not already fitted, attach the blue & red score cubes into the flat top ends with the screws provided. Make sure the ball slopes are fitted inside the table. Finally, fix the ball catcher to the long side of the table as shown below:

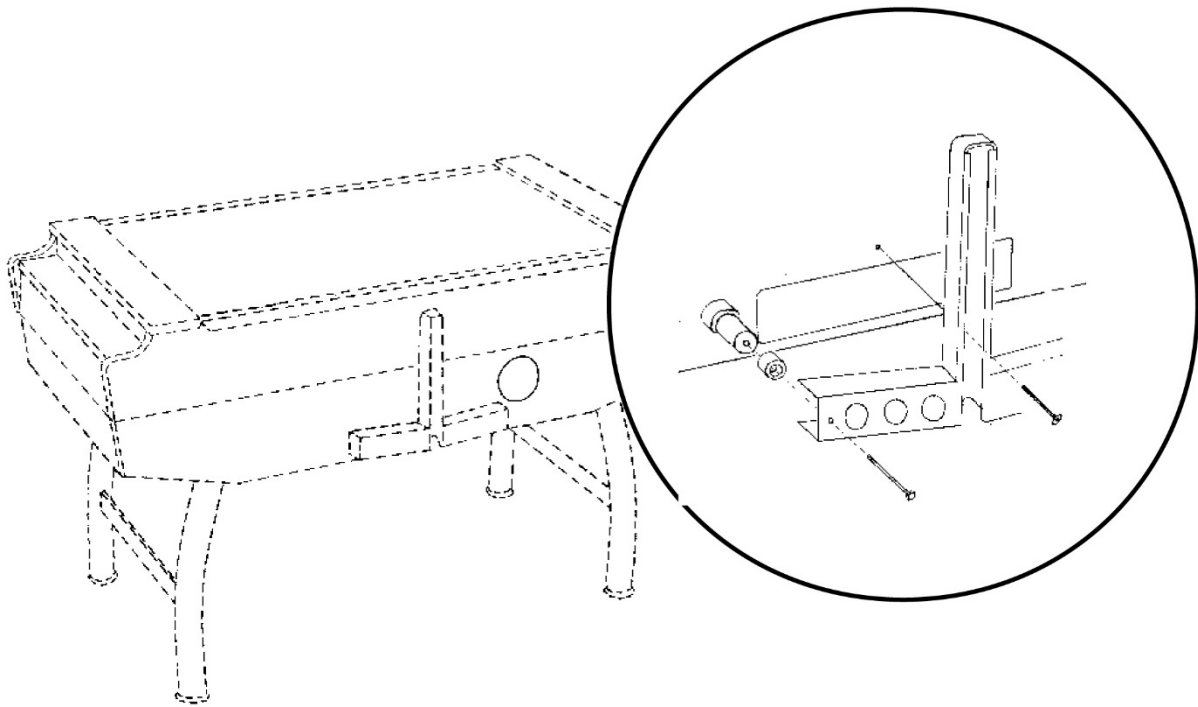

You are now ready to play

Cleaning & Maintenance

Use everyday household glass cleaner for both the glass & the laminate surface.



Mightymast Leisure is the UK & Ireland agent for FAS Italian table football games

For sales & service contact:

Mightymast Leisure Ltd, 58 Bentwaters Park, Rendlesham, Woodbridge, Suffolk. IP12 2TW. UK

Tel: +44 (0)1394-460896

www.mightymast.com

info@mightymast.com